

280 mm  
0,91 ft

o/or

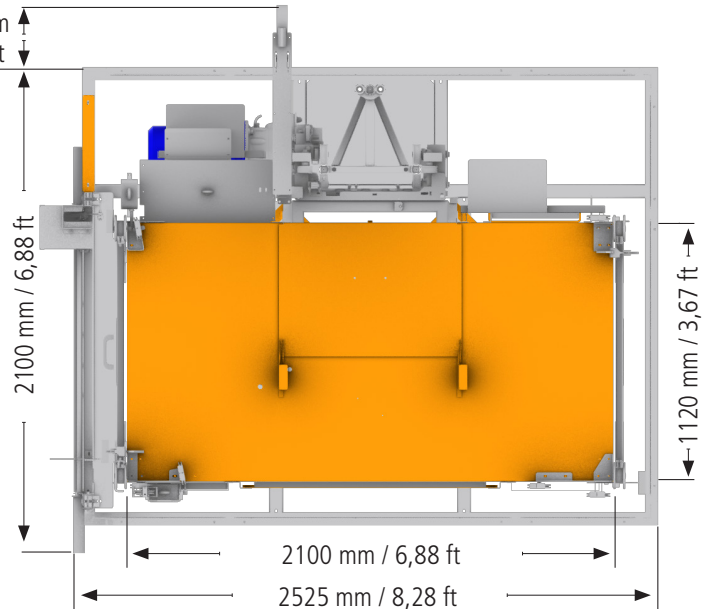

1000 kg  
2205 lb



## DATI TECNICI • TECHNICAL DATA



Capacità con limitatore di carico	Capacity with overload system	Charge avec limiteur de charge	Capacidad con limitador de carga	1000 kg
Velocità di sollevamento	Lifting speed	Vitesse de lévage	Velocidad de elevación	25/30 m/min
Massima altezza ancorata	Max anchored height	Hauter max avec ancrages	Altura max con anclajes	160 m
Dimensioni interne cabina	Internal cage dimensions	Dimensions internes de la cabine	Dimensiones interno cabina	1,12 x 2,09 m
Apertura porte	Doors opening	Overture des portes	Apertura puertas	0,98 x 2 m
Potenza servizio continuo	Power of the motors	Puissance des moteurs	Potencia de motorreductores	2 x 4 kW
Potenza servizio a intermittenza 15%	Rated power intermittence duty 15%	Puissance service intermittence 15%	Potencia servicio intermitencia 15%	2 x 6 kW
Tensione alimentazione	Input power range	Tension d'alimentation	Tensión de red	230/400 V-50 Hz 275/480 V-60 Hz
Interruttore protezione linea	Protection switch	Interrupteur de protection	Interruptor de protección	32 A
Minima potenza di linea consigliata	Minimum line power suggested	Min. puissance de ligne conseillée	Min. potencia linea	12 kW
Peso unità base	Base unit weight	Poids unité de base	Peso unidad de base	1985 kg
Ingrassatore automatico cremagliera	Rack automatic greasing pump	Graisseur automatique de crémaillère	Engrasador automático de cremallera	✓



## COLONNA • MAST

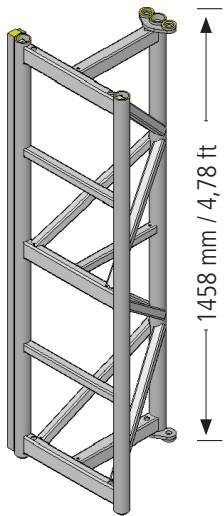

COMPATIBILE CON:  
INTERCHANGEABILITY:

ELSA PM-M 10  
ELSA P26

DISPONIBILE ANCHE CON  
COLONNA RETTANGOLARE

ALSO AVAILABLE WITH  
RECTANGULAR MAST

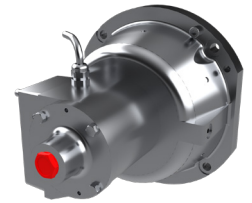
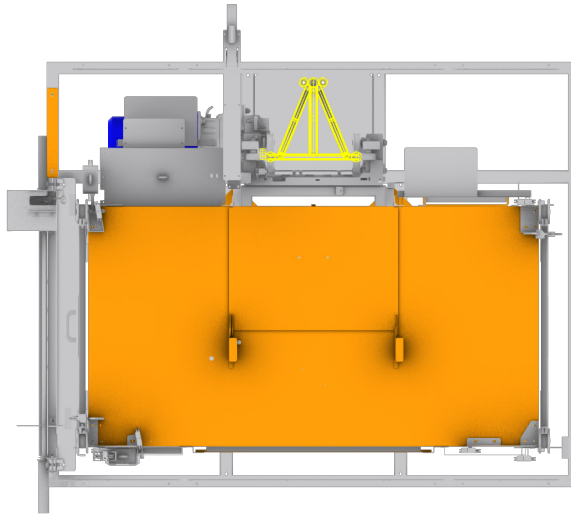

Freno di emergenza ad  
arresto progressivo

Overspeed safety device  
with progressive stop

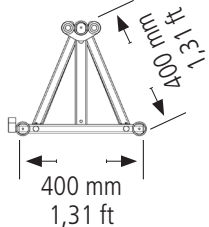

**disponibile anche con  
colonna rettangolare  
available with  
rectangular mast too**

## DATI TECNICI • TECHNICAL DATA



Capacità con limitatore di carico	Capacity with overload system	Charge avec limiteur de charge	Capacidad con limitador de carga	2205 lb
Velocità di sollevamento	Lifting speed	Vitesse de lévage	Velocidad de elevación	82/98 ft/min
Massima altezza ancorata	Max anchored height	Hauter max avec ancrages	Altura max con anclajes	525 ft
Dimensioni interne cabina	Internal cage dimensions	Dimensions internes de la cabine	Dimensiones interno cabina	3,67 x 6,86 ft
Apertura porte	Doors opening	Overture des portes	Apertura puertas	3,21 x 6,56 ft
Potenza servizio continuo	Power of the motors	Puissance des moteurs	Potencia de motorreductores	2 x 4 kW
Potenza servizio a intermittenza 15%	Rated power intermittence duty 15%	Puissance service intermittence 15%	Potencia servicio intermitencia 15%	2 x 6 kW
Tensione alimentazione	Input power range	Tension d'alimentation	Tensión de red	230/400 V-50 Hz 275/480 V-60 Hz
Interruttore protezione linea	Protection switch	Interrupteur de protection	Interruptor de protección	32 A
Minima potenza di linea consigliata	Minimum line power suggested	Min. puissance de ligne conseillée	Min. potencia linea	12 kW
Peso unità base	Base unit weight	Poids unité de base	Peso unidad de base	4376 lb
Ingrassatore automatico cremagliera	Rack automatic greasing pump	Graisser automatique de cremallere	Engrassador automatico de cremallera	✓