

MONOCOLONNA • SINGLE MAST



VERSIONE TRASPORTABILE CON CARRELLO  
TRANSPORTABLE VERSION WITH TRAILER

## DATI TECNICI • TECHNICAL DATA



				P26/8	P26/26	P26/8	P26/26
Massima capacità di carico	Max capacity	Max charge	Máx capacidad de carga	1550 kg	2750 kg	1550 kg	2750 kg
Velocità di sollevamento	Lifting speed	Vitesse de levage	Velocidad de elevación	da 5 a 8 m / min		10 m / min	
Max lunghezza piattaforma	Max platform length	Max longueur plate-forme	Máx longitud de la plataforma	7 m	25,76 m	7 m	25,76 m
Larghezza piattaforma	Platform width	Largeur plate-forme	Ancho de la plataforma	0,8 m		0,8 m	
Larghezza Standard estensioni telesc.	Standard telesc. extension	Long. standard des extensions	Ancho estándar extensiones telesc.	0,8 m		0,8 m	
Larghezza Max estensioni telesc.	Max extension length	Max longueur extensions	Ancho máximo extensiones telesc.	2m* max		2m* max	
Massima altezza libera	Max freestanding height	Hauteur max sans ancrages	Máximo altura libre	5 m		5 m	
Massima altezza ancorata	Max anchored height	Hauteur max avec ancrages	Máximo altura anclada	160 m		160 m	
Intervallo ancoraggi	Max tie distance	Intervalle ancrages	Intervalo ancoraggi	7,5 m max		7,5 m max	
Tensione alimentazione	Input power range	Tension d'alimentation	Tensión de red	220/230 V-50/60 Hz		230/400 V-50 Hz 275/480 V-60 Hz	
Potenza servizio continuo	Power of the motors	Puissance des moteurs	Potencia de motorreductores	1 x 1,1 kW	2 x 1,1 kW	1 x 3 kW	2 x 3 kW
Minima potenza di linea consigliata	Minimum line power suggested	Min. puissance de ligne conseillée	Min. potencia linea	3 kW	3 kW	6 kW	10 kW
Dispositivo paracadute	Parachute safety device	Dispositif de sécurité parachute	Dispositivo paracaídas	✓	✓	✓	✓
Ingrassatore automatico cremagliera	Rack automatic greasing pump	Graisser automatique de cremailiere	Engrasador automatico de cremallera	✓	✓	✓	✓
Sistema di sovraccarico	Overload System	Système de surcharge	Limitador de carga	✓	✓	✓	✓

\* Contattare Platformi.bg / \* Contact Platformi.bg

I dati riportati nelle tabelle sono suscettibili di variazione, in concomitanza ai continui aggiornamenti e miglioramenti delle nostre macchine.  
The data shown in the tables are subject to change, in conjunction with the continuous updates and improvements of our machines.

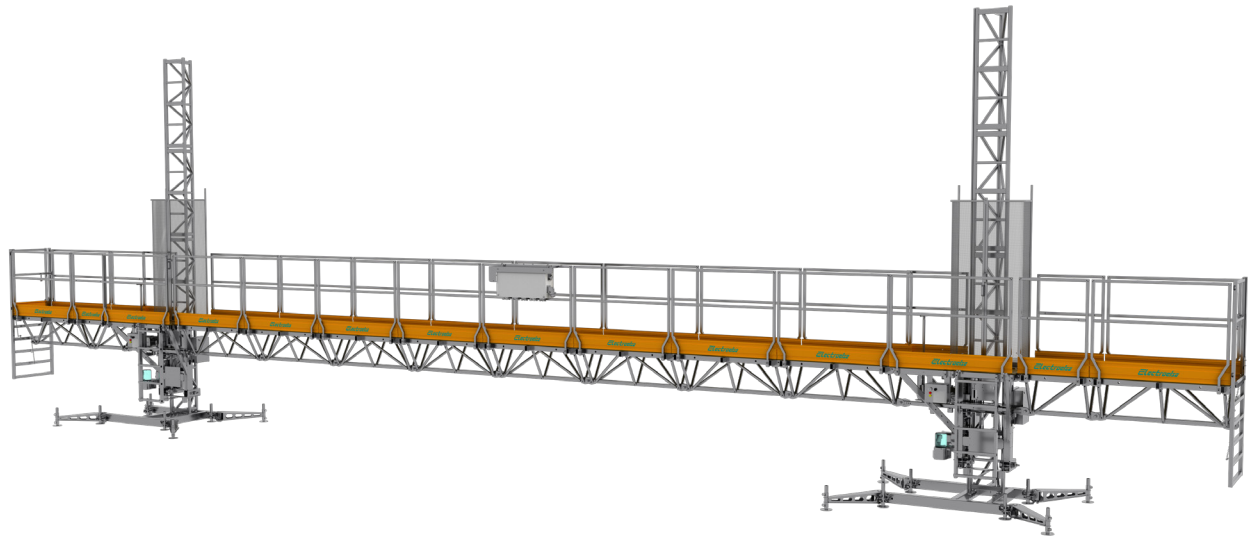

BICOLONNA • TWIN MAST

## DATI TECNICI • TECHNICAL DATA



				P26/8	P26/26	P26/8	P26/26
Massima capacità di carico	Max capacity	Max charge	Máx capacidad de carga	3417 lb	6062 lb	3417 lb	6062 lb
Velocità di sollevamento	Lifting speed	Vitesse de lévage	Velocidad de elevación	da 16,40 a 26,24 ft		32,80 ft / min	
Max lunghezza piattaforma	Max platform length	Max longueur plate-forme	Máx longitud de la plataforma	22,96 ft	84,51 ft	22,96 ft	84,51 ft
Larghezza piattaforma	Platform width	Largeur plate-forme	Ancho de la plataforma	2,62 ft		2,62 ft	
Larghezza Standard estensioni telesc.	Standard telesc. extension	Long. standard des extensions	Ancho estándar extensiones telesc.	2,62 ft		2,62 ft	
Larghezza Max estensioni telesc.	Max extension length	Max longueur extensions	Ancho máximo extensiones telesc.	6,56 ft* max		6,56 ft* max	
Massima altezza libera	Max freestanding height	Hauteur max sans ancrages	Máximo altura libre	16,4 ft		16,4 ft	
Massima altezza ancorata	Max anchored height	Hauteur max avec ancrages	Máximo altura anclada	524,93 ft		524,93 ft	
Intervallo ancoraggi	Max tie distance	Intervalle ancrages	Intervalo ancoraggi	24,60 ft max		24,60 ft max	
Tensione alimentazione	Input power range	Tension d'alimentation	Tensión de red	220/230 V-50/60 Hz		230/400 V-50 Hz 275/480 V-60 Hz	
Potenza servizio continuo	Power of the motors	Puissance des moteurs	Potencia de motorreductores	1 x 1,1 kW	2 x 1,1 kW	1 x 3 kW	2 x 3 kW
Minima potenza di linea consigliata	Minimum line power suggested	Min. puissance de ligne conseillée	Min. potencia linea	3 kW	3 kW	6 kW	10 kW
Dispositivo paracadute	Parachute safety device	Dispositif de sécurité parachute	Dispositivo paracaídas	✓	✓	✓	✓
Ingrassatore automatico cremagliera	Rack automatic greasing pump	Graisseur automatique de cremallere	Engrasador automatico de cremallera	✓	✓	✓	✓
Sistema di sovraccarico	Overload System	Système de surcharge	Limitador de carga	✓	✓	✓	✓

\* Contattare [Platformi.bg](http://Platformi.bg) / \* Contact [Platformi.bg](http://Platformi.bg)



# ELSA P26



PIATTAFORME DI LAVORO AUTOSOLLEVANTI • MAST CLIMBING WORK PLATFORMS

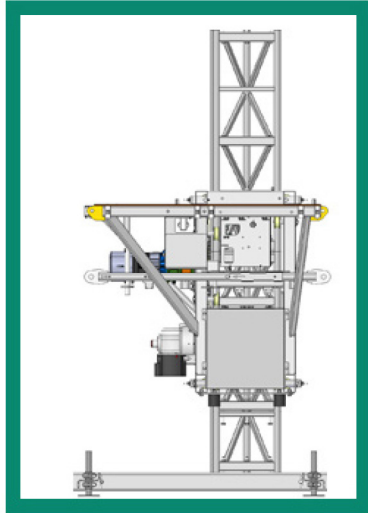

450 kg  
992,08 lb

Max altezza libera dopo ultimo ancoraggio 3m

Max freestanding height over the last wall tie 9,84ft

Intervallo ancoraggio 3/6m  
Mast tie interval min/max 9,84/19,68ft

Max distanza primo ancoraggio 5m  
Max first tie distance 16,4ft

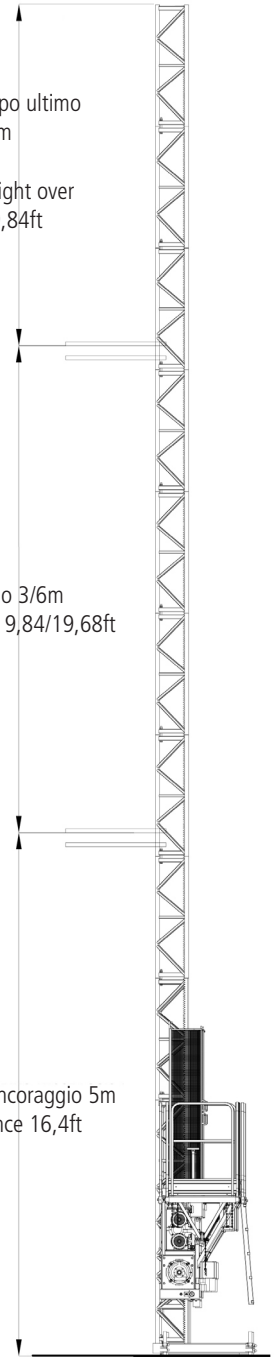
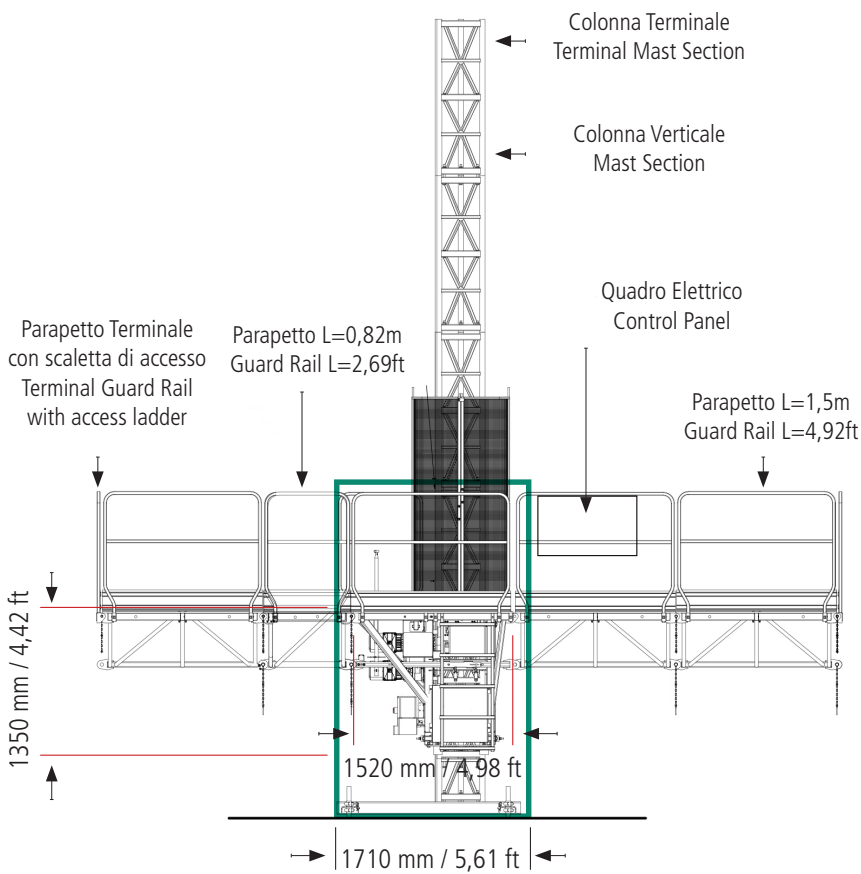

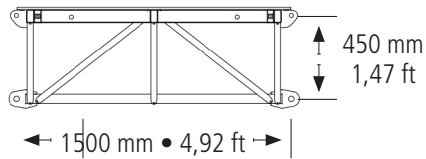

Dettagli modulo ponte  
Deck module details

68 kg  
149 lb

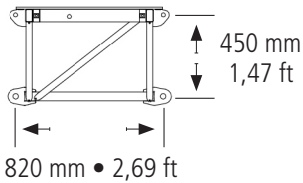

Dettagli modulo ponte  
Deck module details

42 kg  
92 lb

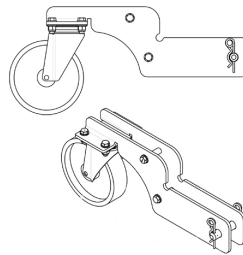

Ruote pivotanti rimovibili  
Removable pivoting wheels

### COLONNA • MAST

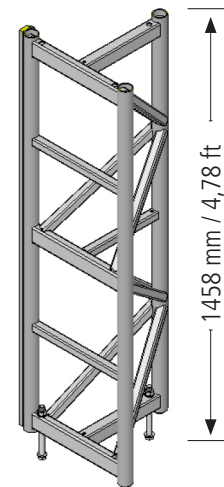

48 kg  
105,82 lb

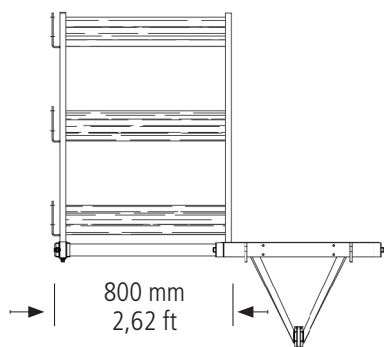

Estensioni a parete standard  
Standard telescopic wall extensions

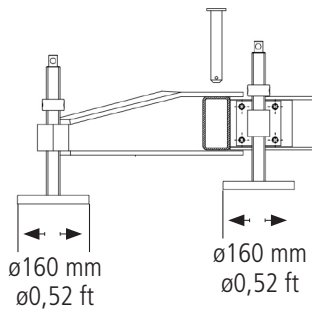

Stabilizzatori rimovibili  
Removable outriggers

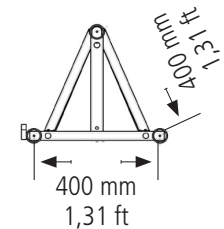

Dettagli colonna verticale  
Mast section details

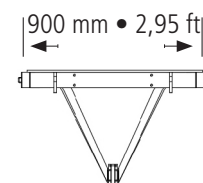

Vista frontale modulo ponte  
Deck module front view

### CARATTERISTICHE • FEATURES

MASSIME SOLLECITAZIONI GRAVANTI SUI PIEDINI A PIENO CARICO  
MAXIMUM LOAD WEIGHING ON THE BASE JACKS BY FULL MOVING LOADED UNIT

Height (m) Altezza (m)	n° mast sections n° sezioni colonne	F (daN)	P [MPa]
10	7	5776	2,5558
20	14	6119	2,7077
30	21	6463	2,8595
40	28	6806	2,0114
50	35	7149	2,1633
60**	42	7492	3,3152
70	49	7836	3,4670
80	55	8130	3,5972
90	62	8473	3,7491
100	69	8816	3,9010
150	103	10483	4,6386
160	110	10827	4,7905

\*\*Per macchine installate ad una altezza maggiore di 50 m il basamento deve poggiare direttamente a terra.

\*\*For machines with installations for heights greater than 50 m the base must always be placed on the ground.

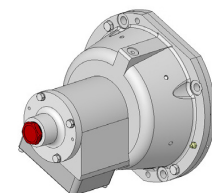

Freno di emergenza ad arresto progressivo

Overspeed safety device with progressive stop



# ELSA P26



PIATTAFORME DI LAVORO AUTOSOLLEVANTI • MAST CLIMBING WORK PLATFORMS

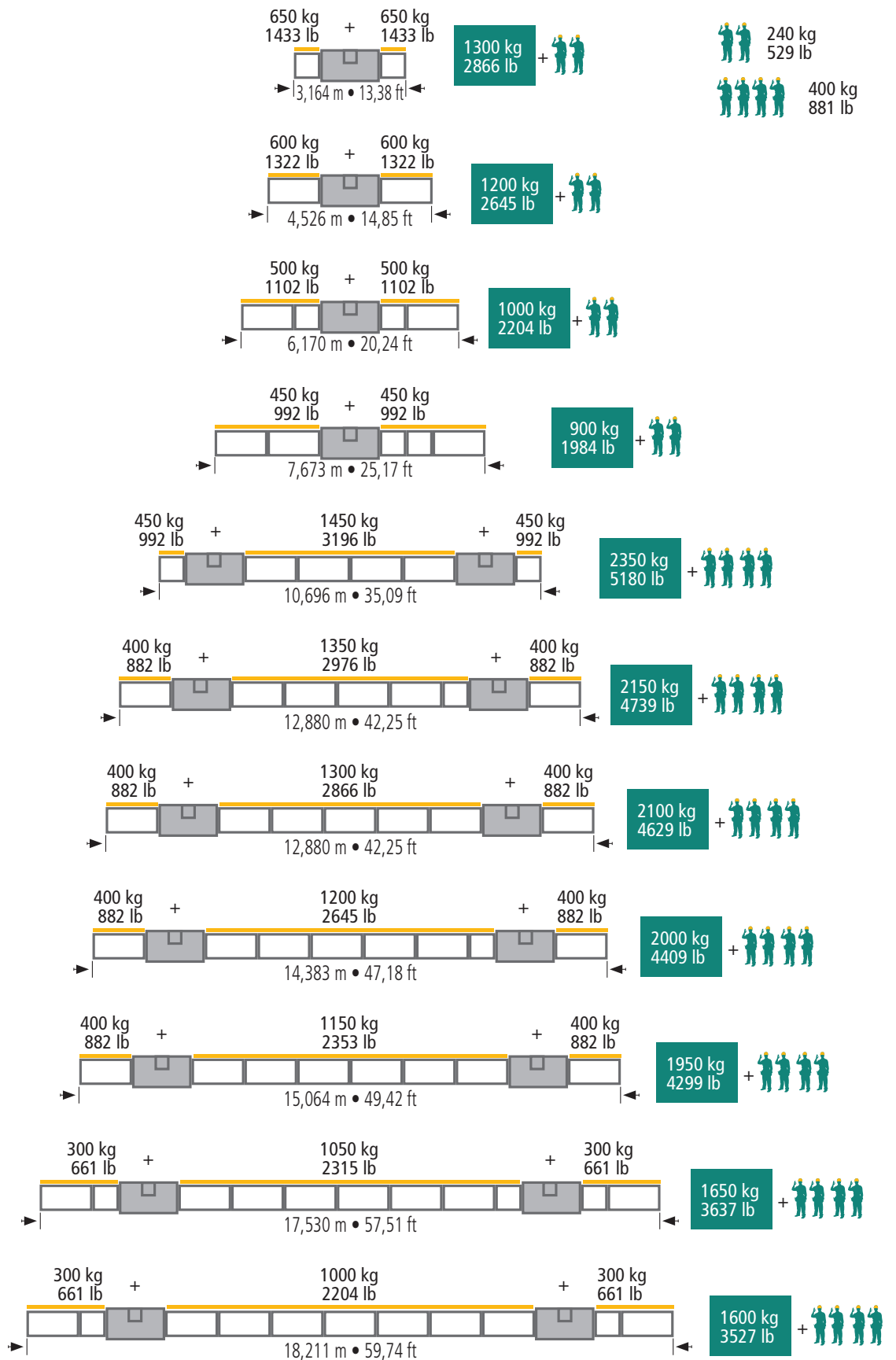



# ELSA P26



PIATTAFORME DI LAVORO AUTOSOLLEVANTI • MAST CLIMBING WORK PLATFORMS

